

CITY and COUNTY PROPOSITIONS

To be voted on at the
GENERAL ELECTION
TUESDAY, NOVEMBER 6, 1956



Published under provisions of Section 183 of the
Charter of the City and County of San Francisco.

Thos. A. Toomey,
Registrar of Voters.

SPECIAL NOTE:

In order to avoid congestion and possible delay at the polls on election day voters are urged to:

1. Use the polling place card enclosed herewith. Mark your choices for the various offices and propositions. TAKE THE CARD WITH YOU TO THE POLLS and you can complete your voting in less than ONE MINUTE.

2. Vote early, if possible.

THOS. A. TOOMEY,
Registrar of Voters.

**Permanent registration is maintained by VOTING.
Voters who fail to vote this year will have their
registration CANCELLED.**

INDEX TO CITY AND COUNTY PROPOSITIONS

Proposition	Page
A. — School Bonds, 1956, \$27,000,000.....	2
B. — Airport Bonds, 1956, \$25,000,000.....	8
C. — Amends Charter relating to contingent fund of the Chief of Police..	13
D. — Amends Charter relating to retirement allowances applicable to certain retired officers and employees.....	15
E. — Amends Charter relating to residence requirements; wages and hours: platform men and coach or bus operators, Municipal Railway	18
F. — Amends Charter relating to retirement and death benefit provisions applicable to certain members of the Fire Department.....	24
G. — Amends Charter relating to appropriations for Utilities.....	28
H. — Amends Charter relating to the appointment of inspectors and assistant inspectors in the Police Department.....	30

PROPOSITION A

School Bonds 1956. To incur a bonded indebtedness in the sum of \$27,000,000 for the acquisition, construction and completion of buildings, lands, structures, remodeling of, and reconstruction and replacement of existing schools, and all other works and properties necessary or convenient for school purposes within San Francisco.

File No. 14596-2

Ordinance No. 9844

(Series of 1939)

CALLING AND PROVIDING FOR A SPECIAL ELECTION TO BE HELD IN THE CITY AND COUNTY OF SAN FRANCISCO ON TUESDAY, NOVEMBER 6, 1956, FOR THE PURPOSE OF SUBMITTING TO THE VOTERS OF THE CITY AND COUNTY OF SAN FRANCISCO A PROPOSITION TO INCUR A BONDED DEBT OF THE CITY AND COUNTY TO THE AMOUNT OF \$27,000,000 FOR THE ACQUISITION, CONSTRUCTION AND COMPLETION BY THE CITY AND COUNTY OF SAN FRANCISCO OF THE FOLLOWING MUNICIPAL IMPROVEMENTS, TO WIT: BUILDINGS, LANDS, STRUCTURES AND ALL OTHER WORKS, PROPERTIES AND APPURTENANCES

NECESSARY OR CONVENIENT FOR SCHOOL PURPOSES WITHIN THE CITY AND COUNTY OF SAN FRANCISCO, INCLUDING ADDITIONS TO, REMODELING OF, AND RECONSTRUCTION AND REPLACEMENT OF EXISTING SCHOOL PROPERTIES, AND THAT THE ESTIMATED COST TO THE CITY AND COUNTY OF SAID MUNICIPAL IMPROVEMENT IS AND WILL BE TOO GREAT TO BE PAID OUT OF THE ORDINARY ANNUAL INCOME AND REVENUE OF THE CITY AND COUNTY AND WILL REQUIRE AN EXPENDITURE GREATER THAN THE AMOUNT ALLOWED THEREFOR BY THE ANNUAL TAX LEVY; ALL IN ORDER TO DO AND PERFORM ANY AND ALL OF THE MATTERS HEREINABOVE REFERRED TO FOR SCHOOL PURPOSES WITHIN THE CITY AND COUNTY OF SAN FRANCISCO; FIXING RATE OF INTEREST OF SAID BONDS AND PROVIDING FOR THE LEVY AND COLLECTION OF TAXES TO PAY BOTH PRINCIPAL AND INTEREST THEREOF, PRESCRIBING NOTICE TO BE GIVEN OF SUCH ELECTION AND CONSOLIDATING THE SPECIAL ELECTION WITH THE GENERAL ELECTION.

Be it ordained by the People of the City and County of San Francisco:

Section 1. A special election is hereby called and ordered to be held in the City and County of San Francisco on Tuesday, the 6th day of November, 1956, for the purpose of submitting to the electors of said city and county a proposition to incur a bonded indebtedness of the City and County of San Francisco in the principal amount of \$27,000,000 for the acquisition, construction and completion by the City and County of San Francisco of the following municipal improvement, to wit: Buildings, lands, structures and all other works, properties and appurtenances necessary or convenient for school purposes within the city and County of San Francisco, including additions to, remodeling of, and reconstruction and replacement of existing school properties.

Section 2. The estimated cost of the municipal improvement described herein was fixed by the Board of Supervisors by Resolution No. 16931 (Series of 1939), passed by more than two-thirds of said board, and approved by the Mayor in the sum of \$27,000,000, and such sum is, and was found by said resolution to be, too great to be paid out of the ordinary annual income and revenue of the city and county, in addition to the other annual expenses thereof or other funds derived from taxes levied for that purpose and will require an expenditure greater than the amount allowed therefor by the annual tax levy.

The method and manner of payment of the estimated cost of the municipal improvement described herein are by the issuance of bonds of the City and County of San Francisco in the principal amount specified in Section 1 hereof.

Section 3. The special election hereby called and ordered to be held shall be held and conducted and the votes thereat received and canvassed, and the returns thereof made and the result thereof ascertained, determined and declared as herein provided and in all particulars not herein recited said election shall be held according to the laws of the State of California providing for and governing elections in the City and County of San Francisco, and the polls for such election shall be and remain open during the time required by said laws.

Section 4. The said special election hereby called shall be and hereby is consolidated with the General Election to be held Tuesday, November 6,

1956, and the voting precincts, polling places and officers of election for said General Election be and the same are hereby adopted, established, designated and named, respectively, as the voting precincts, polling places and officers of election for said special election hereby called, and as specifically set forth, in the official publication, by the Registrar of Voters of precincts, polling places and election officers for the said General Election.

The ballots to be used at said special election shall be the ballots to be used at said General Election and reference is hereby made to the notice of election setting forth the voting precincts, polling places and officers of election by the Registrar of Voters for the General Election to be published in the San Francisco Chronicle on or about October 22, 1956.

Section 5. On the ballots to be used at such special election and on the voting machines used at said special election, in addition to any other matter required by law to be printed thereon, shall appear thereon the following:

"School Bonds, 1956. To incur a bonded indebtedness in the sum of \$27,000,000 for the acquisition, construction and completion of buildings, lands, structures, remodeling of, and reconstruction and replacement of existing schools, and all other works and properties necessary or convenient for school purposes within San Francisco."

To vote for the proposition where ballots are used, and to incur the bonded indebtedness to the amount of and for the purposes stated herein, stamp a cross (x) in the blank space to the right of the word "Yes." To vote against the proposition and thereby refuse to authorize the incurring of a bonded indebtedness to the amount of and for the purposes stated herein, stamp a cross (x) in the blank space to the right of the word "No."

Where voting machines are used at said special election the said voting machines shall be so arranged that any qualified elector may vote for the proposition by pulling down a lever over the word "Yes" under or near a statement of the proposed proposition appearing on cardboard, paper or other material placed on the front of the machine and said act shall constitute a vote for the proposition, and by pulling down a lever over the word "No" under or near a statement of the proposed proposition appearing on cardboard, paper or other material placed on the front of the machine, shall constitute a vote against the proposition. Said voting machines and the preparation of the same shall comply in all respects with the provisions of law.

Section 6. If at such special election it shall appear that two-thirds of all the voters voting on said proposition voted in favor of and authorized the incurring of a bonded indebtedness for the purposes set forth in said proposition, then such proposition shall have been accepted by the electors, and bonds shall be issued to defray the cost of the municipal improvement described herein. Such bonds shall be of the form and character known as "serials," and shall bear interest at a rate not to exceed 6 per centum per annum, payable semiannually.

Section 7. For the purpose of paying the principal and the interest on said bonds, the Board of Supervisors shall, at the time of fixing the general tax levy and in the manner for such general tax levy provided, levy and collect annually each year until such bonds are paid, or until there is a sum in the Treasury of said city and county set apart for that purpose to meet all sums coming due for the principal and interest on said bonds, a tax sufficient to pay the annual interest on such bonds as the same become due and also such part of the principal thereof as shall become due before the proceeds

of a tax levied at the time for making the next general tax levy can be made available for the payment of such principal.

Section 8. This ordinance shall be published once a day for at least seven (7) days in the San Francisco Chronicle, a newspaper published daily in the City and County of San Francisco, being the official newspaper of said city and county and such publication shall constitute notice of said election and no other notice of the election hereby called need be given.

APPROVED as to form:
DION R. HOLM, City Attorney.

Passed for Second Reading—Board of Supervisors, San Francisco, August 13, 1956.

Ayes: Supervisors Blake, Dobbs, Ertola, Ferdon, Halley, McCarty, Rolph, Sullivan.

Absent: Supervisors Casey, McAteer, McMahan.

ROBERT J. DOLAN, Acting Clerk.

Read Second Time and Finally Passed—Board of Supervisors, San Francisco, August 20, 1956.

Ayes: Supervisors Blake, Casey, Dobbs, Halley, McAteer, McCarty, Rolph, Sullivan.

Absent: Supervisors Ertola, Ferdon, McMahan.

I hereby certify that the foregoing ordinance was finally passed by the Board of Supervisors of the City and County of San Francisco.

JOHN R. McGRATH, Clerk.

Approved: August 22, 1956.

GEORGE CHRISTOPHER, Mayor.

ARGUMENT FOR PROPOSITION A

Vote "Yes" on Proposition A for School Bonds

More than 88,000 San Francisco children, from kindergarten through high school, are crowded into 130 school buildings—many of these buildings inadequate, antiquated and subject to condemnation. The number of classrooms and school buildings—aside from the poor condition of many of them—is grossly inadequate to care for present and future needs.

San Francisco's school age population has been increasing at the rate of three per cent per year, and the best estimates indicate that it will continue to do so for years to come. This means that, if we are to give our children the educational advantages to which they are entitled, if their schooling is to be given them in clean, modern, safe buildings—we must authorize sufficient funds now to provide a commensurate school building program.

Our school buildings in use today go back in age to 1895 and some may well be considered hazards to health, safety, and morale. Since 1948 the School Department, in attempting to meet the rapidly mounting needs of our school population, has built 26 new elementary schools, three junior high schools, but no high schools. Three new elementary schools are needed, and additions are needed to three more elementary schools and five junior high schools.

Two new high schools are sorely needed immediately to take care of the increased number of pupils advancing from the lower grades. Two sections of San Francisco—in particular, the Southeast section and the heavily populated Southwest area—have long been in need of high schools.

In addition to the school needs of elementary, junior high and high school children, our junior college—San Francisco City College—with a current enrollment of 6,000 is increasing in numbers and importance, and additional facilities must be provided here as well.

The recommendation for this bond issue for a school building program has been made by the Board of Education after a careful survey of existing facilities, their utilization, and the trends in pupil enrollments by grades and levels and neighborhoods. Maximum utilization of present building space has been figured before planning additional school facilities. Only projects most urgent have been included.

Wherever practical, new classroom needs will be cared for by providing additions to present schools, rather than building new schools, thus keeping down the over-all annual operational and administrative costs.

As a further saving, the School Department already owns vacant property on which to build all but two of the buildings that are planned in this bond issue.

San Francisco will not receive funds from the California State School Bond Issue because that program is designed for school districts which have reached their maximum bonded indebtedness and are, therefore, unable to provide more school buildings. This is not true of San Francisco.

The \$27,000,000 bond issue will be used to meet the following needs:

(1) 2 new high schools, one in the Southeast and one in the Southwest (Lowell) sections of the city.

(2) Completion of the new Silver Avenue Junior High School.

(3) New additions to these junior high schools: Portola, Horace Mann, James Denman, Roosevelt, and Francisco.

(4) New additions to these elementary schools: Golden Gate, Starr King, and Ortega.

(5) Three new elementary schools, one in the Midtown Terrace development, one in the Chinatown-North Beach section, and one to replace the old Longfellow School, which should be abandoned.

(6) An addition to the John O'Connell Trade and Technical School.

(7) Additional physical education and athletic facilities at Lincoln, Balboa, and Washington High Schools.

(8) Additional building facilities at San Francisco City College (Junior College).

(9) Remodeling and reconstruction of numerous existing school buildings, including major work at Polytechnic High School.

(10) Equipment for building projects.

The costs of the projects just listed above have been computed by competent city authorities, and estimates were based on a close study of both the labor and materials markets.

In a world that grows daily more complex—a world in which high educational standards play an increasingly important role—one of our primary and greatest responsibilities is to provide our children with good, sound schooling. To do this we must have schoolrooms—enough schoolrooms to care for all our children, in whatever part of the city they may live, without dangerous overcrowding, or cutting in half the number of hours each day they may attend classes.

The future of San Francisco depends upon the fitness of our young people to assume the obligations of adulthood and citizenship—and upon the

qualities of leadership developed and fostered in the schoolrooms. Give our children enough schools—good schools. Vote "Yes" on Proposition A.

ADRIEN J. FALK, Chairman, Citizens Committee for Better Schools.

ADOLFO de URIOSTE, President, San Francisco Board of Education.

MRS. TONY PATCH, President, San Francisco Second District, California Congress of Parents and Teachers.

HAROLD SPEARS, Superintendent, San Francisco Public Schools.

Vote "Yes" on Proposition A for School Bonds

A "Yes" vote on Proposition "A" is endorsed by:

San Francisco Labor Council; George K. Johns, Secretary.

The San Francisco Municipal Conference, composed of representatives of the following organizations:

Apartment House Association
Building Owners and Managers Association
California Northern Hotel Association
Downtown Association

Retail Dry Goods Association
Retail Merchants Association
San Francisco Chamber of Commerce
Junior Chamber of Commerce
San Francisco Real Estate Board

On September 17, 1956, the Board of Supervisors authorized the foregoing argument for inclusion in the election pamphlet for November 6, 1956, by the following vote:

Ayes: Supervisors Blake, Casey, Dobbs, Ertola, Ferdon, Halley, McAteer, McCarty, McMahan, Rolph, Sullivan.

Noes: None.

JOHN R. McGRATH, Clerk,
Board of Supervisors.

CONTROLLER'S STATEMENT PURSUANT TO CHARTER SECTION 183 PROPOSITION "A"

School Bonds, 1956. To incur a bonded indebtedness in the sum of \$27,000,000 for the acquisition, construction and completion of structures and other works necessary or convenient for school purposes in the City and County of San Francisco.

Should the proposed \$27,000,000 School Bonds, 1956, be authorized and when all bonds shall have been issued, it is estimated that the cost of debt service will be as follows:

Bond redemption requirement.....	\$27,000,000
Interest requirement	5,400,000
	<hr/>
Total debt service requirement.....	\$32,400,000

Based on the Board of Education's estimate of money requirements from the proposed \$27,000,000 bonds, it is estimated that said bonds would be outstanding for an average term of eight years; that said bonds would be issued and sold in unequal amounts at different dates extending over a period of five years; that a portion of said bonds issued and sold would be redeemed annually; that no one bond would be outstanding for more than fifteen years; and that the time elapsed between the sale of the first bond and the redemption of the last bond would be twenty years. It is estimated that the average amount required to pay the interest on said proposed bonds and the redemption thereof would be \$1,620,000 per year for twenty years.

Based on the current assessment roll said amount of \$1,620,000 would be equivalent to an increase of twelve and four tenths cents in the tax rate.

HARRY D. ROSS, Controller,
City and County of San Francisco.

PROPOSITION B

Airport Bonds 1956. To incur a bonded indebtedness in the sum of \$25,000,000 for the acquisition, construction, completion and improvement of San Francisco Airport in San Mateo County.

File No. 14667-2

Ordinance No. 9845

(Series of 1939)

CALLING AND PROVIDING FOR A SPECIAL ELECTION TO BE HELD IN THE CITY AND COUNTY OF SAN FRANCISCO ON TUESDAY, NOVEMBER 6, 1956, FOR THE PURPOSE OF SUBMITTING TO THE VOTERS OF THE CITY AND COUNTY OF SAN FRANCISCO A PROPOSITION TO INCUR A BONDED DEBT OF THE CITY AND COUNTY TO THE AMOUNT OF \$25,000,000 FOR THE ACQUISITION, CONSTRUCTION AND COMPLETION BY THE CITY AND COUNTY OF SAN FRANCISCO OF THE FOLLOWING MUNICIPAL IMPROVEMENT, TO WIT: IMPROVEMENT OF THE SAN FRANCISCO AIRPORT IN SAN MATEO COUNTY, INCLUDING ADDITIONS THERETO SO AS TO PROVIDE THE NECESSARY FACILITIES FOR THE LANDING, TAKING OFF, HOUSING AND HARBORING OF AIRCRAFT ENGAGED IN NATIONAL AND INTERNATIONAL AIR COMMERCE, TOGETHER WITH ALL OTHER PLANES ENGAGED IN AIR COMMERCE PATRONIZING SAID AIRPORT, ADDITIONAL LANDS, OPERATING AREA, RUNWAYS, TAXIWAYS, TURNOUTS, AFRONS AND ROADS; DEVELOPMENT OF MAINTENANCE BASE AREAS; CONSTRUCTION OF AIR CARGO FACILITIES, TERMINAL BUILDING ADDITIONS, HANGARS; IMPROVEMENT OF EXISTING CONCOURSES AND CONSTRUCTION OF NEW CONCOURSES, SECONDARY TERMINAL AND HELIPORT, PARKING FACILITIES INCLUDING PAVING, FIREHOUSE INCLUDING FIRE FIGHTING EQUIPMENT; ADDITIONS TO AIR TERMINAL BUILDING AND OTHER STRUCTURES INCLUDING LIGHTING, DRAINAGE AND SEWER FACILITIES, THE GRADING, FILLING AND PAVING OF ANY PORTION OF SAID AIRPORT; THE IMPROVEMENT OF LIGHTING AND OTHER ADDITIONS TO AIR NAVIGATION, AND ALL OTHER WORKS, PROPERTIES, APPURTENANCES AND EQUIPMENT NECESSARY OR CONVENIENT FOR THE IMPROVEMENT OF SAID AIRPORT, AND THAT THE ESTIMATED COST TO THE CITY AND COUNTY OF SAID MUNICIPAL IMPROVEMENT IS AND WILL BE TOO GREAT TO BE PAID OUT OF THE ORDINARY ANNUAL INCOME AND REVENUE OF THE CITY AND COUNTY AND WILL REQUIRE AN EXPENDITURE GREATER THAN THE AMOUNT ALLOWED THEREFOR BY THE ANNUAL TAX LEVY; ALL IN ORDER TO DO AND PERFORM ANY AND ALL OF THE MATTERS HEREINABOVE REFERRED TO FOR THE IMPROVEMENT OF SAID AIRPORT; FIXING RATE OF INTEREST OF SAID BONDS AND PROVIDING FOR THE LEVY AND COLLECTION OF TAXES TO PAY BOTH PRINCIPAL AND INTEREST THEREOF,

PRESCRIBING NOTICE TO BE GIVEN OF SUCH ELECTION AND CONSOLIDATING THE SPECIAL ELECTION WITH THE GENERAL ELECTION.

Be it Ordained by the People of the City and County of San Francisco:

Section 1. A special election is hereby called and ordered to be held in the City and County of San Francisco on Tuesday, the 6th day of November, 1956, for the purpose of submitting to the electors of said city and county a proposition to incur a bonded indebtedness of the City and County of San Francisco in the principal amount of \$25,000,000 for the acquisition, construction and completion by the City and County of San Francisco of the following municipal improvement, to wit: Improvement of the San Francisco Airport in San Mateo County, including additions thereto so as to provide the necessary facilities for the landing, taking off, housing and harboring of aircraft engaged in national and international air commerce, together with all other planes engaged in air commerce patronizing said airport, additional lands, operating area, runways, taxiways, turnouts, aprons and roads; development of maintenance base areas; construction of air cargo facilities, terminal building additions, hangars; improvement of existing concourses and construction of new concourses, secondary terminal and heliport, parking facilities including paving, firehouse including fire fighting equipment; additions to air terminal building and other structures including lighting, drainage and sewer facilities, the grading, filling and paving of any portion of said airport; the improvement of lighting and other additions to air navigation, and all other works, properties, appurtenances and equipment necessary or convenient for the improvement of said airport.

Section 2. The estimated cost of the municipal improvement described herein was fixed by the Board of Supervisors by Resolution No. 16940 (Series of 1939), passed by more than two-thirds of said board, and approved by the Mayor in the sum of \$25,000,000, and such sum is, and was found by said resolution to be, too great to be paid out of the ordinary annual income and revenue of the city and county in addition to the other annual expenses thereof or other funds derived from taxes levied for that purpose and will require an expenditure greater than the amount allowed therefor by the annual tax levy.

The method and manner of payment of the estimated cost of the municipal improvement described herein are by the issuance of bonds of the City and County of San Francisco in the principal amount specified in Section 1 hereof.

Section 3. The special election hereby called and ordered to be held shall be held and conducted and the votes thereat received and canvassed, and the returns thereof made and the result thereof ascertained, determined and declared as herein provided and in all particulars not herein recited said election shall be held according to the laws of the State of California providing for and governing elections in the City and County of San Francisco, and the polls for such election shall be and remain open during the time required by said laws.

Section 4. The said special election hereby called shall be and hereby is consolidated with the General Election to be held Tuesday, November 6, 1956, and the voting precincts, polling places and officers of election for said General Election be and the same are hereby adopted, established, designated and named, respectively, as the voting precincts, polling places and officers of election for said special election hereby called, and as specifically

set forth, in the official publication, by the Registrar of Voters of precincts, polling places and election officers for the said General Election.

The ballots to be used at said special election shall be the ballots to be used at said General Election and reference is hereby made to the notice of election setting forth the voting precincts, polling places and officers of election by the Registrar of Voters for the General Election to be published in the San Francisco Chronicle on or about October 22, 1956.

Section 5. On the ballots to be used at such special election and on the voting machines used at said special election, in addition to any other matter required by law to be printed thereon, shall appear thereon the following:

"Airport Bonds, 1956. To incur a bonded indebtedness in the sum of \$25,000,000 for the acquisition, construction, completion and improvement of the San Francisco Airport in San Mateo County."

To vote for the proposition where ballots are used, and to incur the bonded indebtedness to the amount of and for the purposes stated herein, stamp a cross (x) in the blank space to the right of the word "Yes." To vote against the proposition and thereby refuse to authorize the incurring of a bonded indebtedness to the amount of and for the purposes stated herein, stamp a cross (x) in the blank space to the right of the word "No."

Where voting machines are used at said special election the said voting machines shall be so arranged that any qualified elector may vote for the proposition by pulling down a lever over the word "Yes" under or near a statement of the proposed proposition appearing on cardboard, paper or other material placed on the front of the machine and said act shall constitute a vote for the proposition, and by pulling down a lever over the word "No" under or near a statement of the proposed proposition appearing on cardboard, paper or other material placed on the front of the machine, shall constitute a vote against the proposition. Said voting machines and the preparation of the same shall comply in all respects with the provisions of law.

Section 6. If at such special election it shall appear that two-thirds of all the voters voting on said proposition voted in favor of and authorized the incurring of a bonded indebtedness for the purposes set forth in said proposition, then such proposition shall have been accepted by the electors, and bonds shall be issued to defray the cost of the municipal improvement described herein. Such bonds shall be of the form and character known as "serials," and shall bear interest at a rate not to exceed 6 per centum per annum, payable semiannually.

Section 7. For the purpose of paying the principal and interest on said bonds, the Board of Supervisors shall, at the time of fixing the general tax levy and in the manner for such general tax levy provided, levy and collect annually each year until such bonds are paid, or until there is a sum in the Treasury of said city and county set apart for that purpose to meet all sums coming due for the principal and interest on said bonds, a tax sufficient to pay the annual interest on such bonds as the same becomes due and also such part of the principal thereof as shall become due before the proceeds of a tax levied at the time for making the next general tax levy can be made available for the payment of such principal.

Section 8. This ordinance shall be published once a day for at least seven (7) days in the San Francisco Chronicle, a newspaper published daily in the City and County of San Francisco, being the official newspaper of

said city and county and such publication shall constitute notice of said election and no other notice of the election hereby called need be given.

APPROVED as to form:

DION R. HOLM, City Attorney.

Passed for Second Reading—Board of Supervisors, San Francisco, August 13, 1956.

Ayes: Supervisors Blake, Dobbs, Ertola, Ferdon, Halley, McCarty, Rolph, Sullivan.

Absent: Supervisors Casey, McAteer, McMahan.

ROBERT J. DOLAN, Acting Clerk.

Read Second Time and Finally Passed—Board of Supervisors, San Francisco, August 20, 1956.

Ayes: Supervisors Blake, Casey, Dobbs, Halley, McAteer, McCarty, Rolph, Sullivan.

Absent: Supervisors Ertola, Ferdon, McMahan.

I hereby certify that the foregoing ordinance was finally passed by the Board of Supervisors of the City and County of San Francisco.

JOHN R. McGRATH, Clerk.

Approved: August 22, 1956.

GEORGE CHRISTOPHER, Mayor.

ARGUMENT FOR PROPOSITION B

Issuance of \$25,000,000 in bonds to meet the challenge of the JET AGE is proposed by Proposition "B," which is designed to accomplish the following objectives:

1. To make San Francisco International Airport wholly free of tax support within four years and thereafter to pay all costs from revenues in addition to yielding net profits averaging more than \$1,000,000 per year.

2. To expand airport facilities in a step-by-step construction program, enabling us to maintain our strong competitive position among the world's leading airports.

3. To meet fully the requirements of commercial jet operation.

Passenger traffic has increased so rapidly at San Francisco International Airport that it now handles well over 3,000,000 per year—a volume previously not expected by 1960. Advent of the JET AGE will bring 5,500,000 passengers by 1960 and over 10,000,000 by 1970.

The capacity of existing facilities is only 4,000,000.

It is imperative that our airport be able to handle these additional millions quickly, comfortably and safely, for the travel dollar is becoming an increasingly important factor in our economy.

In addition, there will be a huge growth in employment and payrolls by private industry servicing expanded passenger and cargo volume. Even today, more than 11,000 persons are privately employed at our airport, commanding an annual payroll of well over \$55,000,000. Scores of millions have been invested privately in building on lands leased from the city.

All this was made possible by previous bond issues approved by the voters. The next step—building for the JET AGE—will vastly increase these private investments, employment and payrolls.

Commercial jet planes, carrying approximately twice the number of passengers at almost twice the speed of today's conventional aircraft, will require longer, sturdier runways; larger, stronger turning areas and taxiways; and numerous auxiliary facilities for handling more people, baggage and cargo.

New concourses, expanded waiting and rest-room facilities, escalators, moving sidewalks, more automobile parking areas, a satellite terminal building, a heliport and additional cargo-handling installations are vital.

All these, and more, can be built and paid for out of revenues—and at a profit.

San Francisco's position in commercial aviation facilities is strong but that position can be maintained only if we meet quickly the physical demands of the JET AGE.

Los Angeles voters, in June, approved an airport expansion bond issue of \$59,700,000 by a six-to-one majority.

This challenge can be met by an affirmative vote on Proposition "B."

It is a business-like approach to the problem of skyrocketing air travel and will pay rich dividends to the taxpayers of San Francisco.

The air race of the great cities of America is on.

Self-interest demands that we maintain San Francisco's position of leadership as the cross-roads of the world's air lanes.

Vote "Yes" on Proposition "B."

City-Wide Committee for the Airport Bonds,
ALAN K. BROWNE, Chairman.

The following organizations, and many others, in the interest of preparing our airport for the JET AGE and making it free of tax support, ask you to Vote "YES" on Proposition "B" for Airport Bonds:

San Francisco Chamber of Commerce
San Francisco Building & Construction Trades Council
San Francisco Labor Council
Apartment House Association of San Francisco, Inc.
Building Owners & Managers Association
California Northern Hotel Association
City and County Grand Jury of 1956
Down Town Association
Mayor's Bond Screening Committee
Retail Dry Goods Association
Retail Merchants Association of the San Francisco Chamber of Commerce
San Francisco Junior Chamber of Commerce
San Francisco Municipal Conference
San Francisco Real Estate Board
Civic League of Improvement Clubs and Associations
Council of Apartment House Associations of San Francisco
Owners and Lessees Apartment House Association, Inc.

On September 17, 1956, the Board of Supervisors authorized the foregoing argument for inclusion in the election pamphlet for November 6, 1956 by the following vote:

Ayes: Supervisors Blake, Casey, Dobbs, Ertola, Ferdon, Halley, McAteer, McCarty, McMahan, Rolph, Sullivan.

Noes: None.

JOHN R. McGRATH, Clerk,
Board of Supervisors.

**CONTROLLER'S STATEMENT PURSUANT TO CHARTER SECTION 183
PROPOSITION "B"**

Airport Bonds, 1956. To incur a bonded indebtedness in the sum of \$25,000,000 for the acquisition, construction and completion of the San Francisco Airport in San Mateo County.

Should the proposed \$25,000,000 Airport Bonds, 1956, be authorized and when all bonds shall have been issued, it is estimated that the cost of debt service will be as follows:

Bond redemption requirement.....	\$25,000,000
Interest requirement	6,319,750
	\$31,319,750
Total debt service requirement.....	\$31,319,750

Based on the Airport's estimate of money requirements from the proposed \$25,000,000 bonds, it is estimated that said bonds would be outstanding for an average term of 10.1 years; that said bonds would be issued and sold in unequal amounts at different dates extending over a period of ten years; that a portion of said bonds issued and sold would be redeemed annually; that no one bond would be outstanding for more than 15 years; and that the time elapsed between the sale of the first bond and the redemption of the last bond would be 25 years. It is estimated that the average amount required to pay the interest on said proposed bonds and the redemption thereof would be \$1,252,790 per year for 25 years.

Based on a projection of Airport revenue at existing rates and charges the estimated debt service requirements for the first 3 years and part of estimated debt service requirement for the fourth year would be financed from ad valorem taxes.

Year	Amount	Effect on Tax Rate Based on Current Assessment Roll
First	\$ 96,000	0.7 cents
Second	322,500	2.5 cents
Third	535,250	4.1 cents
Fourth	160,404	1.2 cents

Commencing with the fifth year and each year thereafter it is estimated that debt service requirements of the proposed \$25,000,000 bonds would be financed entirely from Airport revenues.

HARRY D. ROSS, Controller,
City and County of San Francisco.

**CHARTER AMENDMENT
PROPOSITION C**

Amends Charter Section 35.8; increases amount to \$25,000 that Board of Supervisors may appropriate annually for expenditure by Chief of Police for investigation and detection of crime.

Describing and setting forth a proposal to the qualified electors of the City and County of San Francisco to amend the charter of said city and

county by amending Section 35.8 thereof, relating to the contingent fund of the Police Department.

The Board of Supervisors of the City and County of San Francisco hereby submits to the qualified electors of the City and County of San Francisco at an election to be held therein on November 6, 1956, a proposal to amend the charter of said city and county by amending Section 35.8 thereof, to read as follows:

Note: Additions or substitutions are indicated by **bold-face type**; deletions are indicated by ((double parentheses)).

Section 35.8. The board of supervisors shall ((provide in the annual budget,)) **have the power to appropriate to the police department an amount not to exceed in any one fiscal year the sum of ((\$10,000)) \$25,000 to be known as the contingent fund of the chief of police. The chief of police may from time to time, disburse such sums ((for contingent expenses of the department)) from such fund as in his judgment shall be for the best interests of the city and county ((,)) in the investigation and detection of crime, and the police commission shall allow and order paid out of such contingent fund, upon orders signed by the chief of police, such amounts as may be required.**

Ordered submitted: Board of Supervisors, San Francisco, September 4, 1956.

Ayes: Supervisors Blake, Casey, Dobbs, Ertola, Ferdon, Halley, McAteer, McCarty, Rolph, Sullivan.

Absent: Supervisor McMahan.

I hereby certify that the foregoing charter amendment was ordered submitted by the Board of Supervisors of the City and County of San Francisco.

JOHN R. McGRATH, Clerk.

ARGUMENT FOR PROPOSITION C

Vote "Yes" on Charter Amendment C

This Charter proposal authorizes an increase in the Contingent Fund of the Chief of Police from a maximum of \$10,000 to a maximum of \$25,000 in any one fiscal year.

The Contingent Fund is used chiefly for expenditures of money necessarily incurred by police in undercover investigations. Without such funds, control of vice and vice operators is impossible.

In 1908, when our population was an estimated 403,462, and the personnel strength of the Police Department was 892, the Contingent Fund amounted to \$10,000 for these operations. Today, the population is 807,000 and the personnel of the department numbers 1,810. Yet, with this large increase in population and numerical strength of the department, the Contingent Fund has remained at \$10,000. While this amount was sufficient almost 50 years ago when the investigation of crime was not as complex or costly, it is grossly inadequate today.

Vote "Yes" on Charter Amendment C

On September 17, 1956, the Board of Supervisors authorized the foregoing argument for inclusion in the election pamphlet for November 6, 1956, by the following vote:

Ayes: Supervisors Blake, Casey, Dobbs, Ertola, Ferdon, Halley, McAteer, McCarty, McMahon, Rolph, Sullivan.

Noes: None.

JOHN R. McGRATH, Clerk,
Board of Supervisors.

CONTROLLER'S STATEMENT PURSUANT TO CHARTER SECTION 183 PROPOSITION C

Charter Amendment Section 35.8, Authorizing the Board of Supervisors to Increase the Annual Appropriation for the Contingent Fund of the Chief of Police from \$10,000 to \$25,000.

Should proposition "C" be enacted it would not of itself affect the cost of government of the City and County of San Francisco, but as a product of its application it may increase said cost by \$15,000 annually. Based on the current assessment roll said amount of \$15,000 would be equivalent to slightly more than one-tenth of one cent increase in the tax rate.

HARRY D. ROSS, Controller,
City and County of San Francisco.

CHARTER AMENDMENT PROPOSITION D

Adds Charter Section 165.2.1; increases future monthly retirement allowance payment of employees who retired under Sections 165, 165.2 before July 2, 1952, after 20 years service, by \$25.00 and by proportionately less after less service.

Describing and setting forth a proposal to the qualified electors of the City and County of San Francisco to amend the charter of said city and county by adding Section 165.2.1 thereto, relating to increase in retirement allowances of miscellaneous officers and employees retired under Section 165.2 of the Charter prior to July 2, 1952, and retired under Section 165 of the Charter prior to July 2, 1952, but not prior to July 1, 1952.

The Board of Supervisors of the City and County of San Francisco hereby submits to the qualified electors of the City and County of San Francisco at an election to be held therein on November 6, 1956, a proposal to amend the charter of said city and county by adding thereto Section 165.2.1, to read as follows:

Section 165.2.1. Every retirement allowance payable by the San Francisco City and County Employees' Retirement System, for time commencing on the effective date of this section, hereby designated as the first day of the month next following its ratification by the Legislature, to or on account of any person who was retired prior to July 2, 1952, as a member of said system under Section 165.2, and to or on account of any person who was retired prior to July 2, 1952, but not prior to July 1, 1952, as a member of said system under Section 165, is hereby increased by the amount of \$25 per month, provided such member was entitled to be credited under the

retirement system with at least twenty years of service upon which the retirement allowance was determined at retirement. If the member was entitled to be credited with less than twenty years of such service, then said monthly increase shall be an amount which shall bear the same ratio to \$25 that the service with which the member was entitled to be credited at effective date of retirement, bears to twenty years. This section does not give any member retired prior to the effective date hereof, or his successors in interest, any claim against the city and county for any increase in any retirement allowance paid or payable for time prior to said effective date. If a member elected at retirement to have his retirement allowance modified under Option 2 or 3, provided by ordinance, and if the member and his beneficiary are living on said effective date, the increase in the allowance shall be modified under the option elected at retirement, and on the basis of current ages, mortality tables and interest rate. If the beneficiary of such a person who elected at retirement to have his allowance modified under one of said options is not living on said effective date, or if the retired member is not living on said effective date and the beneficiary is receiving the modified retirement allowance, then the allowance shall be increased as provided herein for persons who did not elect an option.

The increase in the retirement allowance shall be apportioned between service rendered prior to the entry of the member into the retirement system and service rendered as a member, in the same proportion that such prior and current service respectively, bears to the total service credited at retirement. Contributions to the retirement system necessary for the payment of the increases in the retirement allowances provided in this section, shall be provided, with respect to the portion of the benefit based on service rendered as members, from the reserves held by the retirement system on account of miscellaneous members, the necessary amount being transferred upon said effective date, from said reserves to the reserves held by the retirement system to meet the obligations of the city and county on account of benefits that have been granted and on account of prior service of members. The contribution being required of the city and county currently as percentages of salaries of persons who are members under Section 165.2, shall be increased to percentages determined by the actuary as necessary to replace the reserves so transferred. Contributions to the retirement system necessary for the payment of said increases with reference to prior service, shall be paid to the system by the city and county by annual appropriations, provided that such appropriation for any year shall not be less than the amount disbursed during that year on account of said increases.

Ordered submitted: Board of Supervisors, San Francisco, September 4, 1956.

Ayes: Supervisors Blake, Casey, Dobbs, Ertola, Ferdon, Halley, McAteer, McCarty, Rolph, Sullivan.

Absent: Supervisor McMahan.

I hereby certify that the foregoing charter amendment was ordered submitted by the Board of Supervisors of the City and County of San Francisco.

JOHN R. McGRATH, Clerk.

ARGUMENT FOR PROPOSITION D

Vote "Yes" on Proposition "D"—Correct a Gross Injustice!

A "Yes" vote on Proposition "D" corrects a gross injustice to a small group of elderly Retired city employees who were—due to technicalities—

left out of the Retirement increase granted to their fellow retired city employees at last year's election.

A "Yes" vote on Proposition "D" providing a small increase in pensions because:

1. The present pension is not enough to live on.
2. Their savings wiped out by inflation—the cost of living having leaped ahead of their low, well-earned pensions.
3. The overwhelming majority of the Retired employees affected are over 70 years old, and none receive Social Security benefits.
4. The Federal and State Government have substantially increased their retired employees' pensions—in recognition of the increased cost of living . . . yet, these retired city employees have never had any increase in their pensions.

We, the elderly retired city employees are without funds to conduct a campaign. We must rely on the sense of fair play of the voters in San Francisco—for a fair pension, correct a gross injustice. Please, vote "Yes" on "D."

This argument is sponsored by the Retired City Employees Committee.

GEORGE M. KLINGNER, Chairman;
ANTOINETTE MONTGOMERY, Sec'y;
MARY MAUDE MURPHY,
SUSIE CORPSTEIN,
CHARLES F. WALSH.

A "Yes" vote on Proposition "D" is endorsed by:

San Francisco Labor Council
Veterans Political Council
Democratic Assembly of Northern California
San Francisco CIO Industrial Council
Civil Service Association of San Francisco

On September 17, 1956, the Board of Supervisors authorized the foregoing argument for inclusion in the election pamphlet for November 6, 1956, by the following vote:

Ayes: Supervisors Blake, Casey, Dobbs, Ertola, Ferdon, Halley, McAteer, McCarty, McMahan, Rolph, Sullivan.

Noes: None.

JOHN R. McGRATH, Clerk,
Board of Supervisors.

ARGUMENT AGAINST PROPOSITION D

Proposition "D" is another proposal to increase the pension of retired city employees, all at public expense. The San Francisco Municipal Conference asks you to vote against the \$25 monthly addition to pensions that are already liberal. Many of the 1,259 employees who would be benefited are receiving pensions of \$300, \$400 and almost \$500 per month. If only hardship cases were to be given this additional money, it would be another matter!

Voters in the past have approved three such so-called "adjustments" (which were unopposed by The Conference), and have incurred a financial liability of \$7,202,240. The Actuary reports that Proposition "D" would cost \$3,000,708. The first payment would be \$296,529. There is no obligation

to increase the pension payments to these retired employees. A gift of public funds of this kind should be made to hardship cases only.

Vote "No" on Proposition D

This argument is sponsored by The San Francisco Municipal Conference, composed of representatives of the following organizations:

Apartment House Association of
San Francisco
Building Owners and Managers
Association
California Northern Hotel Association

Down Town Association
San Francisco Chamber of Commerce
S. F. Junior Chamber of Commerce
San Francisco Real Estate Board

ARTHUR E. WILKINS, Chairman.

CONTROLLER'S STATEMENT PURSUANT TO CHARTER SECTION 183

PROPOSITION D

Charter Amendment Adding Section 165.2.1, Providing for an Increase of \$25.00 Per Month in Retirement Allowances of Miscellaneous Officers and Employees Retired Under Charter Sections 165 and 165.2.

Should Proposition "D" be enacted the first year's estimated increase in the cost of government of the City and County of San Francisco, according to reports by the San Francisco Employees' Retirement System, would be \$296,529. Present conditions indicate that of this sum \$5,542 would be paid by the San Francisco Water Department and \$3,222 would be paid by the Hetch Hetchy Project, the remainder \$287,765, based on the current assessment roll, would be equivalent to two and two-tenths cents increase in the tax rate for the first year. The Retirement System further reported that these sums would decrease year by year as retired members die.

HARRY D. ROSS, Controller,
City and County of San Francisco.

CHARTER AMENDMENT

PROPOSITION E

Amends Charter Sections 125, 144 and 151.3; reduces hours of employment of, waives residence requirement for applicants as, and establishes hourly rate for, platform men and bus operators of municipal railway.

Describing and setting forth a proposal to the qualified electors of the City and County of San Francisco to amend the charter of said city and county by amending Sections 125, 144 and 151.3, relating to residence requirements, wages and hours of employment of platform men and coach or bus operators on the Municipal Railway.

The Board of Supervisors of the City and County of San Francisco hereby submits to the qualified electors of the said city and county at an election to be held therein on November 6, 1956, a proposal to amend the charter of the said city and county by amending Sections 125, 144 and 151.3 thereof, so that the same shall read as follows:

Note: Additions or substitutions are indicated by **bold-face type**; deletions are indicated by ((double parentheses)).

Employments

Section 125. All employees engaged in public utility work at the time this charter shall go into effect, and who have been permanently appointed to their respective positions in conformity with the civil service provisions of this charter, shall become employees of the public utilities commission under the classification held by each such employee at such time. All persons employed in the operating service of any public utility hereafter acquired by the city and county, at the time the same is taken over by the city and county, and who shall have been so employed for at least one year prior to the date of such acquisition, shall be continued in their respective positions and shall be deemed appointed to such positions, under, and entitled to all the benefits of, the civil service provisions of this charter; provided, however, that no person who is not a citizen of the United States shall be so continued in or appointed to his position. All persons residing outside the city and county claiming the benefit of this provision and who are not engaged on such utility work outside of the limits of the city and county shall be allowed a reasonable time, not exceeding one year, to become residents of the city and county.

Persons employed as platform men or bus operators in the operating department of the municipal railway system shall be subject to the following conditions of employment: The basic hours of labor shall be eight hours, to be completed within ten consecutive hours; there shall be one day of rest in each week of seven days; all labor performed in excess of eight hours in any one day, or six days in any one week, shall be paid for at the rate of time and one-half.

For the fiscal year beginning July 1, 1957, the basic hours of labor shall be eight hours to be completed within ten consecutive hours, provided however, in alternate weeks, there shall be two days of rest, consecutive where practicable, and all labor performed in excess of eight hours in any one day, or after a spread of ten consecutive hours in any one day, or five days in any one of such alternate weeks, shall be paid for at the rate of time and one-half.

For the fiscal year beginning July 1, 1958, and thereafter, the basic hours of labor shall be eight hours, to be completed within ten consecutive hours, and there shall be two days off, consecutive where practicable, in each week. All labor performed in excess of eight hours in any one day, or after a spread of ten consecutive hours in any one day, or five days in any one week, shall be paid for at the rate of time and one-half.

Conductors and motormen may be assigned to duty as bus operators and while assigned to such duty they shall receive the compensation fixed for such service. Such assignment shall be governed by seniority of service, subject to a qualifying test by the railroad management as to competency and to state laws as to qualifications and licensing.

The public utilities commission shall have jurisdiction over the airport now being conducted by the City and County of San Francisco, as well as over any other airport which said city and county may hereafter acquire, maintain or operate. All employees, exclusive of the manager, of the present San Francisco airport, who are actually employed at the present airport operated and maintained by the City and County of San Francisco on the effective date of this amendment and who have been continuously so employed for one year immediately preceding said date shall be continued in

their respective positions as if appointed thereto after examination and certification from a list of eligibles and shall thereafter be governed by and be subject to the civil service provisions of this charter. All said employees so continued in their respective positions shall be eligible for like positions in any other airport hereafter acquired, maintained or operated by the City and County of San Francisco.

Applications

Section 144. Any citizen having the qualifications prescribed by Section 7 of this charter may submit himself for any examination under conditions established by the civil service commission. Provided, however, applicants for positions as motorman, conductor or bus operator on the municipal railway need not be residents of the city and county at the time of application, examination or appointment, but must become residents within the meaning of Section 7 within a reasonable time, not to exceed six months, after completion of the probationary period provided in Section 148. The commission shall advertise in the official paper the time, place and general scope of all examinations for entrance into the public service and may take further appropriate means to interest suitable applicants. When examinations for promotion are to be held, the commission shall give notice thereof to all persons in positions entitling them under the civil service rules, to participate in such examination, by posting information thereof in the office of the commission for a period of ten days and notifying the department concerned.

Basis of Standardization of Compensation of Certain Employees

Section 151.3. Notwithstanding any of the provisions of Section 151 or any other provisions of this charter, whenever any groups or crafts establish a rate of pay for such groups or crafts through collective bargaining agreements with employers employing such groups or crafts, and such rate is recognized and paid throughout the industry and the establishments employing such groups or crafts in San Francisco and the civil service commission shall certify that such rate is generally prevailing for such groups or crafts in private employment in San Francisco pursuant to collective bargaining agreements, the board of supervisors shall have the power and it shall be its duty to fix such rate of pay as the compensations for such groups and crafts engaged in the city and county service. The rate of pay so fixed by the board of supervisors shall be determined on the basis of rates of pay certified by the civil service commission on or prior to April 1st of each year and shall be effective July 1st following; provided, that the civil service commission shall review all such agreements as of July 1st of each year and certify to the board of supervisors on or before the second Monday of July any modifications in rates of pay established thereunder for such crafts or groups as herein provided. The board of supervisors shall thereupon revise the rates of pay for such crafts or groups accordingly and the said revised rates of pay so fixed shall be effective from July 1st of the fiscal year in which such revisions are determined.

Should the budget estimates of the several departments be filed with the controller or transmitted to the mayor before any such report of said civil service commission is received by the board of supervisors, the head of each department affected by such report may amend its budget estimate to comply with the provisions of such report.

Notwithstanding the provisions of Section 151 or any other provisions of this charter the wages of the various classifications of employment of

platform employees and coach or bus operators of the municipal railway shall be determined and fixed, annually as follows:

(a) For the fiscal year beginning July 1, 1957, the basic hourly rate of pay shall be established at \$2.244 per hour, and for the fiscal year beginning July 1, 1958, the basic hourly rate of pay shall be established at \$2.448 per hour.

((A)) (b) On or before the ((second)) first Monday of ((July)) August 1959 and of each year thereafter the civil service commission shall certify to the board of supervisors for each classification of employment the average of the two highest wage ((schedule)) schedules in effect on July 1st of that year for comparable platform employees and coach or bus operators of other surface street railway and bus systems in the ((State of California)) United States operated ((in)) primarily within municipalities having each a population of not less than ((100,000)) 500,000 as determined by the then most recent census taken and published by the director of the census of the United States, and each such system normally employing not less than ((one hundred (100))) four hundred (400) platform employees or coach or bus operators, or platform employees, coach and bus operators.

((B)) (c) The board of supervisors shall thereupon fix a wage schedule for each classification of platform employees and coach and bus operators of the municipal railway which shall be not in excess of the average of the two highest wage ((schedule)) schedules so certified by the civil service commission for each such classification.

((C)) (d) When, in addition to their usual duties, such employees are assigned duties as instructors of platform employees or coach or bus operators they shall receive twenty (20c) cents per hour in addition to the rate of pay to which they are otherwise entitled under the wage schedule as herein provided.

((D)) (e) The rates of pay fixed for platform employees and coach and bus operators as herein provided shall be effective from July 1st of the ((fiscal)) year in which such rates of pay are certified by the civil service commission; and for the fiscal year 1956-1957 the rates of pay specified in the established wage schedules shall be paid to employees in accordance with the classifications of employment to which assigned as provided in the wage schedules adopted ((pursuant to this section;)) for the fiscal year 1956-1957; provided, that the platform employees and bus and coach operators so employed by the municipal railway on ((the effective date of this amendment)) January 11, 1955, shall be paid the maximum rate of pay provided in the wage schedules adopted for ((each year as herein provided)) the fiscal year 1956-1957 regardless of classification to which assigned.

((E)) (f) Platform employees and coach and bus operators shall be paid one and one-half times the rate of pay to which they would otherwise be entitled under the wage schedules as herein provided for all work performed on six days specified as holidays by ordinance of the board of supervisors for such employees.

((F)) (g) The terms wage schedule and wage schedules wherever used in this section are hereby defined and intended to include only the maximum rate of pay provided in each such wage schedule, but shall not include other financial or nonfinancial benefits or conditions of employment.

Not later than the 25th day of July in each year as to groups and crafts, and not later than the 25th day of August as to platform employees and coach or bus operators, the board of supervisors shall have power and it shall be its duty, subject to the fiscal provisions of the charter but, without

reference or amendment to the annual budget, to amend the annual appropriation ordinance and the annual salary ordinance to include the provisions necessary for paying the rates of compensation fixed by the board of supervisors as in this section provided for the then current fiscal year.

On recommendation of the civil service commission the board of supervisors shall establish a rate of pay for trainee platform men and bus or coach operators at a level reflecting the current labor market but below the basic hourly rate for motorman, conductor and bus operator.

((The first fiscal year for which wage schedules in accordance with this section shall be fixed for platform employees and coach and bus operators of the municipal railway shall be the fiscal year beginning July 1st next following the effective date of this amendment, but in any event not earlier than July 1, 1955.))

Ordered submitted: Board of Supervisors, San Francisco, September 4, 1956.

Ayes: Supervisors Blake, Casey, Dobbs, Ertola, Ferdon, Halley, McAteer, McCarty, Rolph, Sullivan.

Absent: Supervisor McMahan.

I hereby certify that the foregoing charter amendment was ordered submitted by the Board of Supervisors of the City and County of San Francisco.

JOHN R. McGRATH, Clerk.

ARGUMENT FOR PROPOSITION E

This proposition grants the Municipal Carmen a five-day week over a period of 2 years. Presently the carmen work 48 hours a week. Under this proposition the work-week would be reduced to 44 hours in 1957 and 40 hours in 1958.

The San Francisco carmen and bus operators are the only sizeable group of city employees required to work a 6-day week. Not only are they required to work a 6-day week, but they also must work, in many instances, over a wide span of hours, completing their 8 hours of work each day over a span of 10 hours. This leaves them little time for their families, recreation and leisure.

Vote "Yes" on Proposition E

Under the sponsorship of the Mayor, a committee composed of taxpayer representatives, employer representatives and labor groups studied the problems of the Municipal Carmen. It was the unanimous opinion of this committee that the carmen were entitled to a five-day week. This proposition has instituted a 5-day week in gradual steps over a 2-year period in order to reduce the cost to the community.

Vote "Yes" on Proposition E

Almost every streetcar and bus company in the state of California and of comparable size in the country grants streetcar men and bus operators a 5-day week. This amendment would merely grant carmen working conditions equal to those enjoyed on other comparable bus and transit systems.

This proposition would enable improved recruiting service, because there is presently a great shortage of bus and streetcar drivers.

Vote "Yes" on Proposition E

At the request of the Mayor and taxpayer groups, amendments were made in the bill to reduce the cost of the proposal as originally submitted and to make it acceptable to all segments of the community.

A "Yes" vote on Proposition E is endorsed by the Mayor, the San Francisco Labor Council, the AFL and CIO Municipal Carmen and other civic groups. The proposition is endorsed by the San Francisco Municipal Conference consisting of the following members:

Apartment House Association
Building Owners and Managers Association
California Northern Hotel Association
Downtown Association

Retail Dry Goods Association
Retail Merchants Association
San Francisco Chamber of Commerce
Junior Chamber of Commerce
San Francisco Real Estate Board

Vote "Yes" on Proposition E

The Board of Supervisors unanimously approved the submission of this proposition to the voters.

A "Yes" vote on Proposition "E" is endorsed by:

San Francisco Transportation League
San Francisco CIO Industrial Council
San Francisco Federation of Municipal Employees, Inc.

On September 17, 1956, the Board of Supervisors authorized the foregoing argument for inclusion in the election pamphlet for November 6, 1956, by the following vote:

Ayes: Supervisors Blake, Casey, Dobbs, Ertola, Ferdon, Halley, McAteer, McCarty, McMahon, Rolph, Sullivan.

Noes: None.

JOHN R. McGRATH, Clerk,
Board of Supervisors.

CONTROLLER'S STATEMENT PURSUANT TO CHARTER SECTION 183 PROPOSITION E

Charter Amendment, Sections 125, 144 and 151.3, Fixing Basic Hours of Labor, Days of Rest in the Work Week, Providing a Formula for Application of Overtime Pay Rate, Providing Residential Requirements, Fixing Rates of Pay for the Fiscal Years Beginning July 1, 1957, and 1958, Providing a Method of Fixing Rates of Pay Commencing July 1, 1959, and Providing for Establishment of a Lower Rate of Pay for Trainees, All of Which Relating to Platform Men, Bus or Coach Operators of the Municipal Railway.

Should Proposition "E" be enacted, premised on basic data furnished by the Municipal Railway and based upon the rates of pay provided in this proposition compared with existing rates of pay effective for the fiscal year ending June 30, 1957, and exclusive of the pay formulae provided in Sections 151.3 (b), 151.3 (c) and 151.3 (g), (the products of which are unpredictable at this time) it is estimated that the cost of government of the City and County of San Francisco would be increased as follows:

For the fiscal year beginning July 1, 1957, compared with the current fiscal year beginning July 1, 1956, said cost of government would be increased by approximately \$700,000 if all of the needed manpower will be recruited or somewhere between this \$700,000 and \$900,000 depending upon the extent of recruitment of needed manpower.

For the fiscal year beginning July 1, 1958, compared with the current fiscal year beginning July 1, 1956, said cost of government would be increased by approximately \$1,800,000 if all of the needed manpower will be recruited or somewhere between this \$1,800,000 and \$2,200,000 depending upon the extent of recruitment of needed manpower.

For the fiscal years beginning July 1, 1959, and thereafter, compared with the current fiscal year beginning July 1, 1956, said cost of government would be increased by an amount not now estimable because the product of the wage rate formula provided in this proposition for the years beginning July 1, 1959, cannot be determined.

Based on the current assessment roll, the effect upon the tax rate of aforesaid estimated amounts, would be an increase as follows:

For the fiscal year beginning July 1, 1957, compared with the current fiscal year beginning July 1, 1956, said tax rate would be increased somewhere between five and four-tenths cents and six and nine-tenths cents.

For the fiscal year beginning July 1, 1958, compared with the current fiscal year beginning July 1, 1956, said tax rate would be increased somewhere between thirteen and eight-tenths cents and sixteen and nine-tenths cents.

HARRY D. ROSS, Controller,
City and County of San Francisco.

CHARTER AMENDMENT PROPOSITION F

Amends Charter Sections 171.1.5 and 171.1.7 and adds Section 171.1.5.1; provides pensions for widows of retired members of fire department and adjusts and changes pensions and death benefits of retired firemen.

Describing and setting forth a proposal to the qualified electors of the City and County of San Francisco to amend the charter of said city and county by amending Sections 171.1.5 and 171.1.7 thereof, and by adding Section 171.1.5.1 thereto, relating to retirement and death benefit provisions applicable to certain members of the Fire Department.

The Board of Supervisors of the City and County of San Francisco hereby submits to the qualified electors of said city and county at an election to be held therein on November 6, 1956, a proposal to amend the charter of said city and county by amending Sections 171.1.5 and 171.1.7 thereof, and by adding Section 171.1.5.1 thereto, reading as follows:

Note: Additions or substitutions are indicated by bold-face type; deletions are indicated by ((double parentheses)).

Section 171.1.5. Upon the death of a member resulting from any cause, **other than an injury received in or illness caused by performance of duty,** (a) **if his death occurred after qualification for service retirement, under Section 171.1.2, or after retirement for service, ((or because of disability which resulted from injury received in, or illness caused by performance of duty, and if death shall result from other cause than such injury or illness,))** one-half of his retirement allowance to which the member would have been entitled if he had retired for service at the time of death or one-half of the retirement allowance as it was at his death, as the case may be, shall be continued throughout life or until remarriage, to his surviving

wife ((.)), or (b) if his death occurred, after retirement for disability by reason of injury received in or illness caused by performance of duty, his retirement allowance as it was at his death shall be continued throughout life or until remarriage, to his surviving wife, except that, if death occurred prior to qualification for service retirement allowance, the allowance continued shall be reduced upon the date at which said member would have qualified for service retirement, in the same manner as it would have been reduced had the member not died. If there be no surviving wife entitled to an allowance hereunder, or if she die or remarry before every child of such deceased member attains the age of eighteen years, then the allowance which the surviving wife would have received had she lived and not remarried shall be paid to his child or children under said age, collectively, to continue until every such child dies or attains said age, provided that no child shall receive any allowance after marrying or attaining the age of eighteen years. Should said member leave no surviving wife and no children under the age of eighteen years, but leave a parent or parents dependent upon him for support, the parents so dependent shall collectively receive a monthly allowance equal to that which a surviving wife otherwise would have received, during such dependency. No allowance, however, shall be paid under this section to a surviving wife unless she was married to the member prior to the date of the injury or onset of the illness which ((was incurred in performance of duty and which)) results in death if he had not retired, or ((if death does not result from such injury or illness,)) unless she was married to the member at least one year prior to his retirement.

The surviving wife, in the event of death of the member after qualification for but before service retirement, may elect before the first payment of the allowance, to receive the benefit provided in Section 171.1.7, in lieu of the allowance which otherwise would be continued to her under this section. If there be no surviving wife, the guardian of the child or children under age eighteen, may make such election, and if there be no such children, the dependent parent or parents may make such election. Persons heretofore retired under Charter Section 171, as members of the fire department at the time of retirement, shall be subject to the provisions of this section. "Qualified for service retirement," "Qualification for service retirement" or "Qualified as to age and service for retirement," as used in this section and other sections to which persons who are members under Section 171.1 are subject, shall mean completion of thirty years of service regardless of age, or twenty-five years of service and attainment of age fifty-five, said service to be computed under Section 171.1.9.

The effective date of this amendment shall be the first day of the month following approval by the State Legislature.

Section 171.1.5.1. Every allowance based on the average monthly compensation earnable by the member during the ten years prior to retirement, and payable for time commencing on the effective date of this section, to or on account of persons who were retired, as members under Section 171, for disability resulting from bodily injury received in the performance of duty, shall be adjusted to the amount it would be, if it had been based on the monthly compensation fixed by the board of supervisors as of July 1, 1956, for the rank or position held by such retired member in the fire department prior to retirement. This section does not authorize any decrease in any allowance from the amount being paid at said effective date, nor does this section give any retired member, or any beneficiary of such member, or his successors in interest, any claim against the city and county for

any increase in any allowance paid or payable for the time prior to its effective date. Adjustment in reserves under allowances which are changed according to this section, shall be made on the basis of current interest rate and mortality tables.

The increase in the retirement allowance shall be apportioned according to service rendered by the member in the same manner that the allowance prior to increase was apportioned. Contributions to the retirement system, necessary for the payment of the increase of the portion of the retirement allowances which is paid from reserves held by the retirement system, shall be provided from the reserves held by the retirement system on account of members under Section 171.1, the necessary amount being transferred upon said effective date, from said reserves to the reserves held by the retirement system to meet the obligations on account of benefits that have been granted and on account of prior service of members. The contribution being required of the city and county currently, as a percentage of salaries of persons who are members under Section 171.1, shall be increased to a percentage determined by the actuary as necessary to replace the reserves so transferred. Contributions to the retirement system necessary for the payment of said increases with reference to current and prior service portions of the allowances which are not paid from reserves held by the retirement system, shall be paid to the system by the city and county by annual appropriations, provided that such appropriation for any year shall not be less than the amount disbursed during that year on account of said increases. The effective date of this section shall be the first day of the month following approval by the State Legislature.

Section 171.1.7. If a member of the fire department shall die, before retirement, from causes other than an injury received in or illness caused by the performance of duty, or regardless of cause, if no allowance shall be payable under section 171.1.4 or 171.1.5 preceding, a death benefit shall be paid to his estate or designated beneficiary, the amount of which and the conditions for the payment of which shall be determined in the manner prescribed by the board of supervisors for the death benefit of other members of the retirement system. Upon the death of a member after retirement and regardless of the cause of death, ((the sum of five hundred dollars)) a death benefit shall be paid to his estate or designated beneficiary ((in the manner and subject to the conditions)) the amount of which and the conditions for the payment of which shall be determined in the manner prescribed by the board of supervisors for the ((payment of a similar benefit upon the death of other retired members)) death benefit of other members of the retirement system. The effective date of this amendment shall be the first day of the month following approval by the State Legislature.

Ordered submitted: Board of Supervisors, San Francisco; September 4, 1956.

Ayes: Supervisors Blake, Casey, Dobbs, Ertola, Ferdon, Halley, McAteer, McCarty, Rolph, Sullivan.

Absent: Supervisor McMahan.

I hereby certify that the foregoing charter amendment was ordered submitted by the Board of Supervisors of the City and County of San Francisco.

JOHN R. McGRATH, Clerk.

ARGUMENT FOR PROPOSITION F

Proposition F corrects present inadequate retirement allowance of members of the Fire Department retired prior to 1949 for disabilities incurred in line of duty.

Provides death benefit after retirement in the same manner as for other city employees, i.e., determined by the Board of Supervisors.

Adjusts the retirement allowance for widows and orphans of members of the Fire Department retired for injuries sustained in line of duty.

This argument is sponsored by S. F. Fire Fighters, Local No. 798, AFL-CIO.

R. F. CALLAHAN, Secretary.

A "Yes" vote on Proposition "F" is endorsed by:

George Christopher, Mayor
San Francisco Labor Council

On September 17, 1956, the Board of Supervisors authorized the foregoing argument for inclusion in the election pamphlet for November 6, 1956, by the following vote:

Ayes: Supervisors Blake, Casey, Dobbs, Ertola, Ferdon, Halley, McAteer, McCarty, McMahan, Rolph, Sullivan.

Noes: None.

JOHN R. McGRATH, Clerk,
Board of Supervisors.

ARGUMENT AGAINST PROPOSITION F

Three expensive changes are proposed by Proposition "F." Survivors of a fireman retired for disability would continue to receive his full pension allowance regardless of cause of death, seven retired firemen would have their pensions more than doubled and the death benefit for the entire department would be increased. The city actuary reports the total cost of Proposition "F" for the department at over \$1,100,000. The first year's cost would be \$99,882.

If Proposition "F" is not defeated, the police will have every reason to request increased benefits next year.

The fire and police pension plans now provide handsome benefits. The city now contributes an amount equal to 26.6 per cent of the firemen's salaries to the retirement system to provide present benefits. The taxpayers will pay \$4,711,808 for firemen's pensions this year.

We ask that you vote "No" on Proposition "F" to keep this tremendous cost of firemen's pensions from soaring higher!

This argument is sponsored by The San Francisco Municipal Conference, composed of representatives of the following organizations:

Apartment House Association of
San Francisco

Building Owners and Managers
Association

California Northern Hotel Association

Down Town Association

San Francisco Chamber of Commerce

S. F. Junior Chamber of Commerce

San Francisco Real Estate Board

ARTHUR E. WILKINS, Chairman.

CONTROLLER'S STATEMENT PURSUANT TO CHARTER SECTION 183

PROPOSITION F

Charter Amendment Sections 171.5, 171.1.5.1 (Added) and 171.1.7, Relating to Retirement and Death Benefits for Members of the Fire Department.

Should Proposition "F" be enacted, the increase in the cost of government of the City and County of San Francisco, according to a report by the San Francisco Employees' Retirement System, is estimated to be \$99,882 annually. Based on the current assessment roll, said amount of \$99,882 would be equivalent to eight-tenths of one cent increase in the tax rate.

HARRY D. ROSS, Controller,
City and County of San Francisco.

CHARTER AMENDMENT

PROPOSITION G

Amends Charter Section 74; provides that any utility budget where expenditures exceed estimated revenues a sum not to exceed $\frac{3}{4}\text{¢}$ on each \$100 valuation of property may be included for capital costs.

Describing and setting forth a proposal to the qualified electors of the City and County of San Francisco to amend the charter of said city and county by amending Section 74 thereof, relating to appropriations to meet utility deficits.

The Board of Supervisors of the City and County of San Francisco hereby submits to the qualified electors of the City and County of San Francisco at an election to be held therein on November 6, 1956, a proposal to amend the charter of said city and county by amending Section 74 thereof, so that the same shall read as follows:

Note: Additions or substitutions are indicated by **bold-face type**; deletions are indicated by ((double parentheses)).

Appropriations to Meet Utility Deficits

Section 74. In the event the public utilities commission and the mayor shall propose a budget for any utility which will exceed the estimated revenue of such utility, it shall require a vote of two-thirds of all members of the board of supervisors to approve such budget estimate and to appropriate the funds necessary to provide for the deficiency. ((No such budget of expenditures in excess of estimated revenues shall be so approved to provide for and include proposed expenditures for additions, betterments, extensions or other capital costs, which shall require financing by authorization and sale of bonds.)) **Such budget of expenditures in excess of estimated revenues may be approved to provide for and include proposed expenditures for additions, betterments, extensions or other capital costs, in amount not to exceed three-quarters of one cent (\$.0075) on each one hundred dollars (\$100) valuation of property assessed in and subject to taxation by the city and county, provided that whenever tax support is required for additions,**

betterments, extensions or other capital costs the total provision for such purposes shall not exceed an amount equivalent to three-quarters of one cent (\$.0075) on each one hundred dollars (\$100) valuation of property subject to taxation by the city and county and provided further that proposed expenditures for additions, betterments, extensions or other capital costs in excess thereof shall require financing by authorization and sale of bonds. This section shall have precedence over Section 127 of this charter and any other section deemed in conflict herewith.

Ordered submitted: Board of Supervisors, San Francisco, September 4, 1956.

Ayes: Supervisors Blake, Casey, Dobbs, Ertola, Halley, McAteer, McCarty, Rolph, Sullivan.

No: Supervisor Ferdon.

Absent: Supervisor McMahan.

I hereby certify that the foregoing charter amendment was ordered submitted by the Board of Supervisors of the City and County of San Francisco.

JOHN R. McGRATH, Clerk.

ARGUMENT FOR PROPOSITION G

Vote "Yes" on Proposition G

This charter amendment would make it possible for a municipal utility which is not self-supporting to make minor capital improvements without resorting to the time-consuming and costly procedure of passage of a bond issue, as now required under Section 74 of the Charter.

Under the present Charter provision, a tax supported utility cannot purchase an additional typewriter, or a service truck, without asking the citizens to approve bonds.

Of course it is right and proper that large capital improvements be sanctioned by our citizen-taxpayers. But minor improvements are another matter.

For example, for a small expenditure a turn-around facility could have been installed on the M (Ocean View) line, so modern streetcars could be leased to replace worn-out present equipment on that route, adding to the convenience of the riding public.

It would seem proper that a small amount should be made available to a tax supported utility for minor—and much needed—capital costs.

The charter amendment proposed would allow $\frac{3}{4}$ of 1 cent in the tax rate for each tax supported utility for capital costs. There would still be the normal budgetary checks on any such proposed expenditures, that is, review by the Mayor and the Board of Supervisors.

A "Yes" vote on Proposition "G" is respectfully urged.

On September 17, 1956, the Board of Supervisors authorized the foregoing argument for inclusion in the election pamphlet for November 6, 1956, by the following vote:

Ayes: Supervisors Blake, Casey, Dobbs, Ertola, Halley, McAteer, McCarty, McMahan, Rolph, Sullivan.

No: Supervisor Ferdon.

JOHN R. McGRATH, Clerk,
Board of Supervisors.

CONTROLLER'S STATEMENT PURSUANT TO CHARTER SECTION 183

PROPOSITION G

Charter Amendment, Section 74, Providing That Deficit Utility Budgets May Include Proposed Capital Expenditures Not in Excess of Three-Quarters of One Cent in the Tax Rate.

Should Proposition "G" be enacted it would permit a maximum increase in the cost of government of the City and County of San Francisco, based on the current assessment roll, estimated at

\$ 97,914 for the San Francisco International Airport
97,914 for the Municipal Railway

\$195,828 Total

The provision in Proposition "G" for a maximum tax support of three-quarters of one cent per one hundred dollars assessed valuation for capital purposes for each of the two above-mentioned utilities would be equivalent to one and one-half cents increase in the tax rate for each year such an allowance was made.

It is our judgment that the San Francisco Water Department and the Hetch Hetchy Project would not be affected by Proposition "G."

HARRY D. ROSS, Controller,
City and County of San Francisco.

CHARTER AMENDMENT

PROPOSITION H

Amends Charter Section 35.3; provides for the appointment of inspectors and assistant inspectors in Juvenile Bureau, Accident Prevention Bureau, Bureau of Special Services and Intelligence Unit of police department.

Describing and setting forth a proposal to the qualified electors of the City and County of San Francisco to amend the charter of said city and county by amending Section 35.3 thereof, relating to the appointment of assistant inspectors and inspectors.

The Board of Supervisors of the City and County of San Francisco hereby submits to the qualified electors of the City and County of San Francisco at an election to be held therein on November 6, 1956, a proposal to amend the charter of said city and county by amending Section 35.3 thereof, to read as follows:

Note: Additions or substitutions are indicated by bold-face type; deletions are indicated by ((double parentheses)).

Section 35.3. The Chief of Police may detail from time to time members of the department for performance of duty in the Bureau of Inspectors, the Juvenile Bureau, the Accident Investigation Bureau, the Bureau of Special Services, and the Intelligence Unit, who shall be known as Assistant

Inspectors, and who may be removed from such detail by order of the Chief of Police. An appointment as Inspector shall not be subject to competitive examination ((, but)). In case of vacancy in said rank of Inspector in the Bureau of Inspectors, the appointment shall be made by the Chief of Police from among those Assistant Inspectors who have been detailed to, and who have actually served with the Bureau of Inspectors for at least two years prior to such appointment. The Chief of Police may appoint Inspectors in the Juvenile Bureau, the Accident Investigation Bureau, the Bureau of Special Services, and the Intelligence Unit; such appointments shall be made from among those Assistant Inspectors who have been detailed to, and have actually served as such Assistant Inspectors in the bureau or unit in which the appointment is made for at least two (2) years prior to such appointment. The number of Inspectors at any one time in the Juvenile Bureau, the Accident Investigation Bureau, the Bureau of Special Services, and the Intelligence Unit shall not be greater than a total of twenty-five (25) inspectors.

Inspectors and Assistant Inspectors shall have the same rights as other members of the department to take competitive examinations from their respective civil service ranks. An inspector guilty of any offense or violation of the rules and regulations of the police department shall be subject to punishment as provided in Section 155 of this charter; provided, however, that in addition to the punishments set forth in Section 155, an inspector may be demoted to his civil service rank for any offense or violation set forth in said section and after trial and hearing before the police commission as set forth therein. The chief of police, in addition to the inspectors above provided for, shall detail any member of the department to serve as inspector of school traffic patrols who shall have the rank and pay of inspector, subject to the provisions of this section.

Ordered submitted: Board of Supervisors, San Francisco, September 4, 1956.

Ayes: Supervisors Blake, Casey, Dobbs, Ertola, Ferdon, Halley, McAteer, McCarty, Rolph, Sullivan.

Absent: Supervisor McMahan.

I hereby certify that the foregoing charter amendment was ordered submitted by the Board of Supervisors of the City and County of San Francisco.

JOHN R. McGRATH, Clerk.

ARGUMENT FOR PROPOSITION H

Vote "Yes" on Charter Amendment H

Under the present Charter, inspectors may be appointed only in the Bureau of Inspectors (the detective bureau). The proposed Charter Amendment authorizes the appointment of a maximum of 25 inspectors in four other departments, namely, the Police Juvenile Bureau, the Accident Investigation Bureau, the Bureau of Special Services and the Intelligence Unit, after two years' service therein.

The Charter Amendment will correct an injustice being done to members of these four additional bureaus. Crimes investigated by them include crimes committed against children, hit and run automobile accidents, vice and racketeering. These units do investigative work equal in importance and in danger to that of the Bureau of Inspectors.

Members working in these units have acquired valuable experience and have become experts in their fields, and it is the desire of the Police Department to keep them on their present assignments.

Equivalent opportunity for advancement for equivalent work is all that is being asked.

San Francisco deserves the best in police service.

A vote for Charter Amendment "H" is a vote for better police protection against the child molester, the narcotic peddler, the hit and run driver and the racketeer.

You can help by voting "Yes" on Charter Amendment "H."

Vote "Yes" on Charter Amendment "H"

On September 17, 1956, the Board of Supervisors authorized the foregoing argument for inclusion in the election pamphlet for November 6, 1956, by the following vote:

Ayes: Supervisors Blake, Casey, Dobbs, Ertola, Ferdon, Halley, McAteer, McCarty, McMahon, Rolph, Sullivan.

Noes: None.

JOHN R. McGRATH, Clerk,
Board of Supervisors.

CONTROLLER'S STATEMENT PURSUANT TO CHARTER SECTION 183 PROPOSITION H

Charter Amendment Section 35.3 Relating to Appointment of Inspectors and Assistant Inspectors in the Police Department.

Should Proposition "H" be enacted, it will not of itself affect the cost of government of the City and County of San Francisco, but as a product of its application, based on current wage levels, it is estimated that said proposition may after two years increase said cost by \$24,000 annually. Based on the current assessment roll said amount of \$24,000 would be equivalent to an increase of two-tenths of one cent in the tax rate.









HARRY D. ROSS, Controller,
City and County of San Francisco.



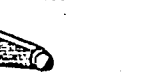





PHILLIPS & VAN ORDEN COMPANY

22 SAMPLE BALLOT

GENERAL PRESIDENT



	1	2	3	4	5	6	7	8	9	10	11	12	13
--	---	---	---	---	---	---	---	---	---	----	----	----	----

 PROPOSITION FOR 1 AGAINST	 PROPOSITION YES 2 NO	 PROPOSITION YES 3 NO	 PROPOSITION YES 4 NO	 PROPOSITION YES 5 NO	 PROPOSITION YES 6 NO	 PROPOSITION YES 7 NO	 PRC YES
VETERANS BOND ACT OF 1956. Act provides for a bond issue of \$500,000,000 to be used by Department of Veterans Affairs in assisting California war veterans to acquire farms and homes.	SCHOOL BONDS. Constitutional Amendment. Authorizes sale of \$100,000,000 of state bonds to provide loans and grants to school districts for school buildings and sites.	STATE CONSTRUCTION BONDS. Constitutional Amendment. Authorizes \$200,000,000 state bond issue to finance buildings for state educational, mental, correctional institutions and other facilities. Earmarks \$60,000,000 for state colleges.	OIL AND GAS CONSERVATION. Initiative. Establishes procedure for unitizing oil and gas pools. Creates Oil and Gas Conservation Commission with regulatory powers.	ALCOHOLIC BEVERAGE ESTABLISHMENTS. Constitutional Amendment. Authorizes service of alcoholic beverages in licensed public premises not serving food.	CHURCH EXEMPTION. Constitutional Amendment. Extends tax exemption for churches to include church parking lots exclusively used as such.	STATE LEGISLATURE. Constitutional Amendment. Changes name of Assembly of the California Legislature to House of Representatives.	LEGISLATIONS. Commission. Direct convene in March. Per budget bill i

 PROPOSITION YES A NO	 PROPOSITION YES B NO	 PROPOSITION YES C NO	 PROPOSITION YES D NO	 PROPOSITION YES E NO	 PROPOSITION YES F NO	 PROPOSITION YES G NO	 PRC YES
SCHOOL BONDS' 1956. To incur a bonded indebtedness in the sum of \$27,000,000 for the acquisition, construction and completion of buildings, lands, structures, remodeling of, and reconstruction and replacement of existing schools, and all other works and properties necessary or convenient for school purposes within San Francisco.	AIRPORT BONDS 1956. To incur a bonded indebtedness in the sum of \$25,000,000 for the acquisition, construction, completion and improvement of San Francisco Airport in San Mateo County.	Amends Charter Section 35.8; increases amount to \$25,000 that Board of Supervisors may appropriate annually for expenditure by Chief of Police for investigation and detection of crime.	Adds Charter Section 165.2.1; increases future monthly retirement allowance payment of employees who retired under Sections 165, 165.2 before July 2, 1952 after 20 years service, by \$25.00 and by proportionately less after less service.	Amends Charter Sections 125, 144 and 151.3; reduces hours of employment of, waives residence requirement for applicants as, and establishes hourly rate for, platform men and bus operators of municipal railway.	Amends Charter Sections 171.1.5 and 171.1.7 and adds Section 171.1.5.1; provides pensions for widows of retired members of fire department and adjusts and changes pensions and death benefits of retired firemen.	Amends Charter Section 74; provides that any utility budget where expenditures exceed estimated revenues a sum not to exceed 3/4% on each \$100 valuation of property may be included for capital costs.	Amends Charter provides for inspectors and in Juvenile Prevention Special Serv Unit of poli







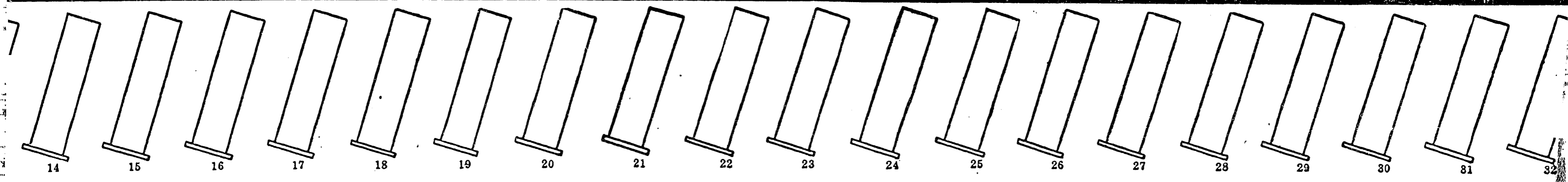

PRESIDENTIAL ELECTORS

Vote for ONE Party

 DWIGHT D. EISENHOWER for President RICHARD M. NIXON for Vice President REPUBLICAN	 ENOCH A. HOLTWICK for President EDWIN M. COOPER for Vice President PROHIBITION	 ADLAI E. STEVENSON for President ESTES KEFAUVER for Vice President DEMOCRATIC
--	---	--

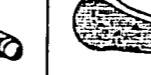
TIAL ELECTION AND SPECIAL MUNICIPAL ELECTION













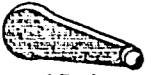

 PROPOSITION 8 NO BUDGET SESSIONS. Constitutional Amendment. Defers budget session to February instead of permits recess after introduction.	 PROPOSITION 9 YES NO COUNTY BOROUGHS. Constitutional Amendment. Authorizes chartered counties to establish borough form of government for all or part of county.	 PROPOSITION 10 YES NO STATE CIVIL SERVICE. Constitutional Amendment. Qualifies civil service requirements by permitting State to employ contract architects and engineers when obtainable state staff cannot do work in time.	 PROPOSITION 11 YES NO FRAMING COUNTY CHARTERS. Constitutional Amendment. Allows freeholders one year, instead of six months, for preparing new county charter.	 PROPOSITION 12 YES NO STATE INDEBTEDNESS. Constitutional Amendment. Fixes maximum term of statutory state bond issues at 50 years. Eliminates three-month advertising of bond propositions.	 PROPOSITION 13 YES NO REPEALING ALIEN LAND LAW. Repeals initiative law of 1920 which formerly denied aliens ineligible to citizenship the right to hold California real estate.	 PROPOSITION 14 YES NO LEGISLATIVE EMPLOYEES. Constitutional Amendment. Deletes existing limitations on method of hiring legislative employees and amount of legislative payroll during sessions.	 PROPOSITION 15 YES NO MUTUAL WATER COMPANIES. Constitutional Amendment. Authorizes public agencies to hold mutual water company shares to secure public water supplies.
---	--	---	--	---	---	--	---

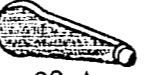
PROPOSITION
16 NO
 Charter Section 35.3; the appointment of assistant inspectors Bureau, Accident Bureau, Bureau of Licenses and Intelligence Bureau department.





CITY & COUNTY PROPOSITIONS

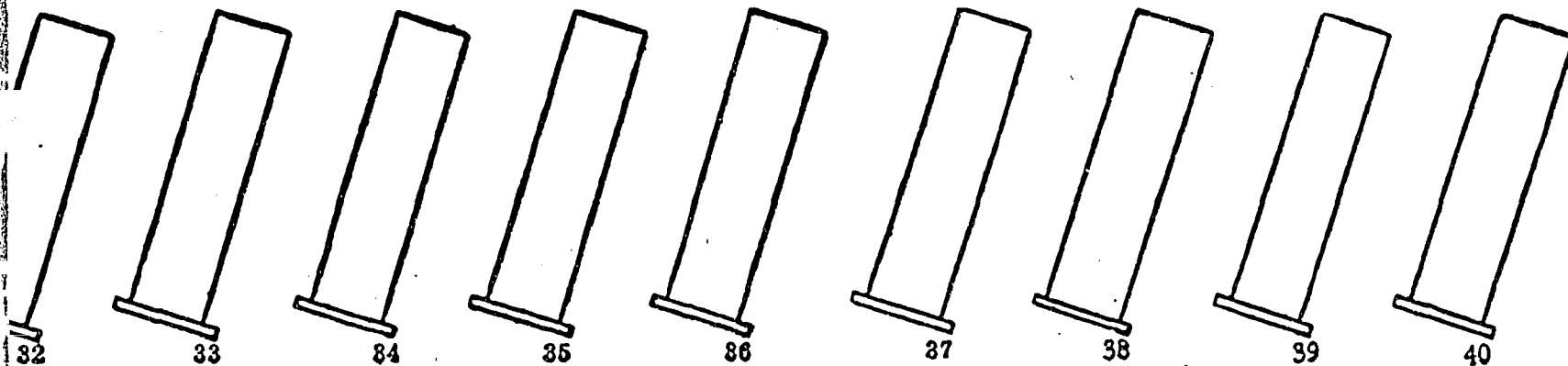

STUDY SAMPLE BALLOT CAREFULLY.
 MARK YOUR CHOICES ON POLLING PLACE CARD.
 TAKE CARD TO POLLING PLACE.
 POLLS OPEN 7 A.M. — CLOSE 8 P.M.
VOTE EARLY



16 UNITED STATES SENATOR VOTE FOR ONE			17 REPRESENTATIVE IN CONGRESS 4th District VOTE FOR ONE		18 MEMBER OF ASSEMBLY 22nd District VOTE FOR ONE		19 ASSOCIATE JUSTICE, SUPREME COURT		20 ASSOCIATE JUSTICE, DISTRICT COURT OF APPEAL First Appellate District Division Two		21 JUDGE, SUPERIOR COURT Office No. 9 VOTE FOR ONE		22 MEMBER BOARD OF EDUCATION Nominated by Mayor for confirmation by Electors.	
 16-A Thomas H. Kuchel Republican United States Senator	 17-A Richard Richards Democratic California State Senator	 18-A Ray Gourley Prohibition Business Man	 19-A William S. Mailliard Republican United States Congressman	 20-A James L. Quigley Democratic Instructor	 21-A Bernard R. Brady Democratic Incumbent	 22-A John A. Busterud Republican Attorney	 23-A YES	 24-A NO Shall Marshall F. McComb be elected to the office for the term prescribed by law?	 25-A YES	 26-A NO Shall Herbert C. Kaufman be elected to the office for the term prescribed by law?	 27-A Alvin E. Weinberger Judge, Municipal Court	 28-A Raymond J. Arata Judge, Municipal Court	 29-A YES	 30-A NO Mrs. Lawrence Draper, Jr.



 <p>PROPOSITION YES 16 NO</p> <p>CIVIL AND CRIMINAL APPEALS. Constitutional Amendment. Authorizes Judicial Council to fix time limits for ordering hearing by Supreme Court.</p>	 <p>PROPOSITION YES 17 NO</p> <p>JUDICIARY. Constitutional Amendment. Repeals constitutional provisions formerly regulating judicial salaries and dealing with former Supreme Court Commission.</p>	 <p>PROPOSITION YES 18 NO</p> <p>INFERIOR COURTS. Constitutional Amendment. Under certain circumstances permits non-lawyer judge of justice court to succeed to judgeship of superseding municipal court.</p>	 <p>PROPOSITION YES 19 NO</p> <p>STATE BOUNDARIES. Constitutional Amendment. Empowers Legislature to alter state boundaries in cooperation with adjoining states, subject to Congress' approval.</p>
--	---	---	--

STATE PROPOSITIONS



31	32
<p>MEMBER BOARD OF EDUCATION</p>	
<p>Nominated by Mayor for confirmation by Electors.</p>	
	
<p>31-A YES</p>	<p>32-A NO</p>
<p>Joseph A. Moore, Jr.</p>	

DIRECTIONS FOR VOTING

1. Move **RED HANDLE LEVER** of voting machine to the **RIGHT** as far as it will go and **LEAVE IT THERE.**
2. To vote **FOR** or **AGAINST** propositions or **FOR** or **AGAINST** confirmation of member of Board of Education, or **FOR** or **AGAINST** Justices of the Supreme Court and District Court of Appeal, pull down pointers over words indicating your choice and **LEAVE THEM DOWN.**
3. To vote for all of the electors of a party pull down the pointer over the names of the presidential and vice presidential candidates of that party and **LEAVE IT DOWN.**
4. To vote **FOR** candidate for United States Senator, Representative in Congress, Member of Assembly and Judge of the Superior Court, pull down pointer over the name of your choice and **LEAVE IT DOWN.**
5. To vote for those electors who have pledged themselves to vote for a candidate for President and for Vice President of any party not qualified to participate in the election, write in the names and party of those presidential and vice presidential candidates in the blank space provided for that purpose in the upper left hand corner of the machine — under square slide #1.
6. To vote for a person whose name does not appear on the ballot label card, **RAISE NUMBERED SLIDE AT TOP OF MACHINE** corresponding to number of office on office title card, and **WRITE NAME** of candidate on paper under slide. **DO NOT** pull down pointer over name of any candidate in office group in which you intend to write in name of a candidate.
7. **LEAVE THE POINTERS DOWN** and move the **RED HANDLE LEVER** to the **LEFT** as far as it will go. Your vote is not registered until this is done.
8. If in doubt as to operating the voting machine, request instructions from the inspector or judge of the election board before attempting to vote.